



Total Food-Service Solutions

Modular Cooking – Outdoor

Electric Teppanyaki

NETY 10-60 Mobile (A)

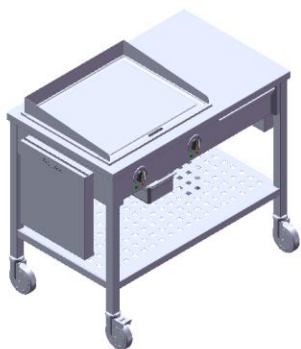

*Due to routine technical improvement, the photograph shown may not represent the latest design of the products.

AVAILABLE MODEL

1. NETY 10-60 Mobile (A)

DESCRIPTION

Portable Mobile Electric Teppanyaki with 3.3 kW. Energized with SSS Heating System for stable and un-fluctuated heating performance. Controlled with Thermostat for temperature management with 2 heating zones. Equipped with grooved edge for oil collection and drainage. Installed on legs with under shelves and wheel. Complemented with drawer and knife holder and working counter table.

ITEM# : _____

MODEL# : _____

NAME : _____

SN : _____

MAIN FEATURE

- Griddle made from solid Stainless Steel 420 Knife Steel
- SSS Griddle Heating System.
- Self-Closing Drawer
- Hygienic Design
- Perforated Under Shelf
- Removable knives holder provided.
- Table extension converted from the knives holder.

CONSTRUCTION

- All exterior panels in 304 type of Stainless Steel.
- Top Panel is constructed of 1.5 mm of Stainless Steel.
- Under shelf is constructed of 1.2 mm of Stainless Steel
- Apron is constructed of 2.0 mm of Stainless Steel.
- Material Griddle is SS420 (t = 16mm).

INCLUDED ACCESSORIES

- Electrical cords with plug.
- Food Pan 1/3 GN x 65 mm.
- Food Pan 1/2 GN x 65 mm.
- Food Pan 1/4 GN x 65 mm.

OPTIONAL ACCESSORIES

- N/A

The company reserves the right to make modifications to the products without prior notice. All information correct at time of printing. 2018.10.16



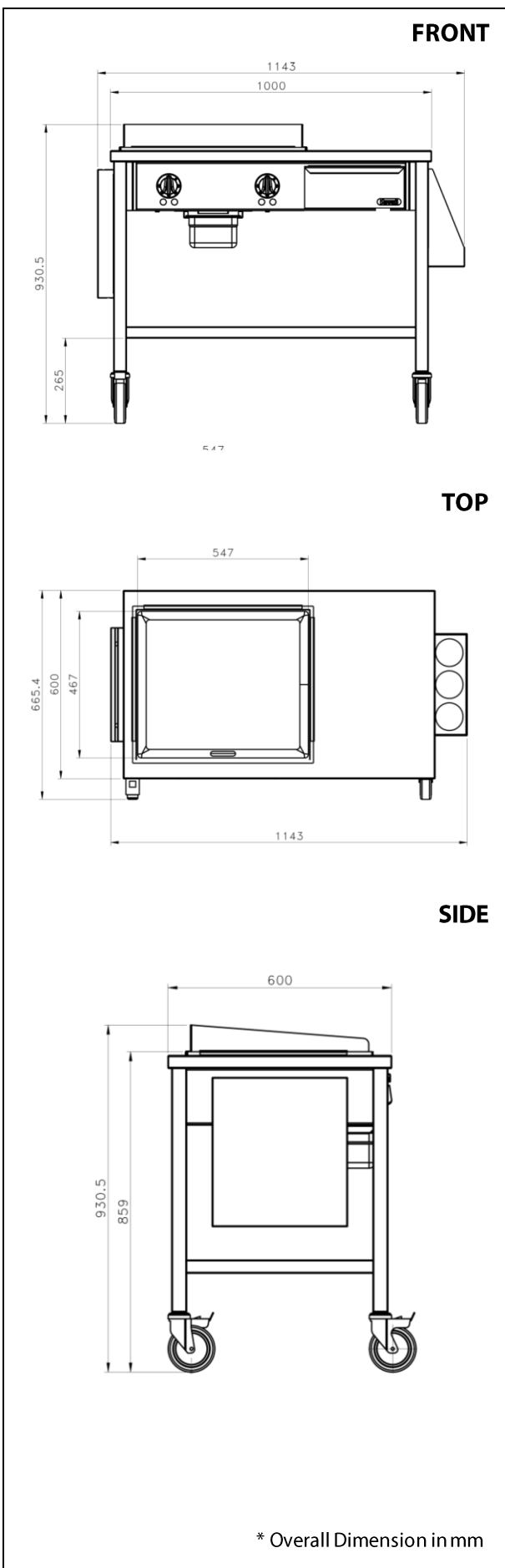

ELECTRIC

Electrical rating (kW)	:	3.3
Element rating (kW)	:	3.3
Electrical supply voltage	:	230V 1N
Required electrical supply (amps):		15
Power Cable	:	
~ Cable Type	:	H05VV-F
~ Cable Dimension	:	3 x 1.5mm ²
Electrical current split (amps)	:	L1: 15

KEY INFORMATION

Unit Dimension (WxDxH)	:	1000x600x850 mm
Cooking surface (WxD)	:	580 x 500 mm
Direct heat emission	:	1.09 kW
Latent heat emission	:	1.32 kW
Steam emission	:	1.94 kg / h
MIN working temperature	:	50°C
MAX working temperature	:	250°C
Temperature control	:	2
Net weight	:	90 kg

PACKING DETAILS

Shipping width	:	1080 mm
Shipping depth	:	680 mm
Shipping height	:	1050 mm
Shipping volume	:	0.771 m ³
Gross weight	:	121 kg

The company reserves the right to make modifications to the products without prior notice. All information correct at time of printing. 2018.10.16